

iNFINITY RT

Tipo-N

Modulo bifacciale con doppio vetro

DMxxxM10RT-B60HBT

490~510W

23,1%
Efficienza massima

- **Qualità eccellente**
Piu' 40 anni di esperienza nella produzione ad alta tecnologia.
- **Elevata responsabilità ambientale, sociale e di governance (ESG)**
100% di Produzione ecosostenibile, catena di fornitura trasparente e eccellenti rating ESG nell'industria solare.

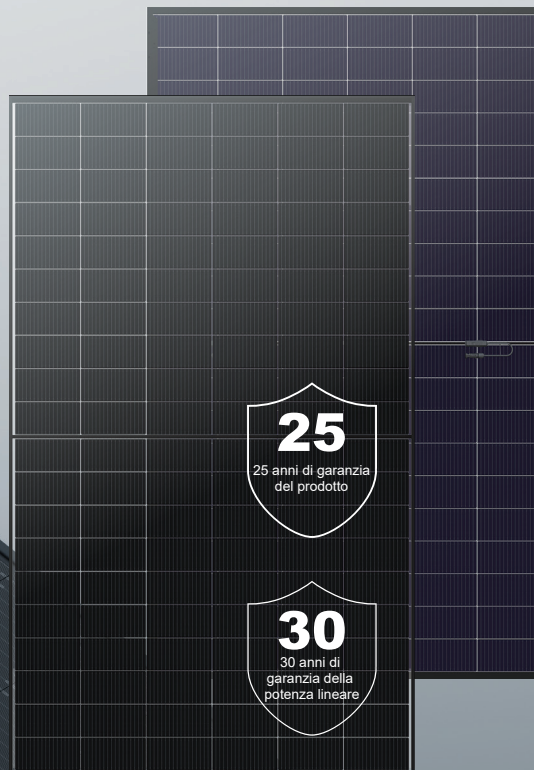

Estetica eccezionale

Estetica alla base della progettazione utilizzando DMEGC Advanced Black Technology.



Prove di pressione estese

Protezione contro le condizioni ambientali avverse
Certificato da TÜV Rheinland.



Produzione ecosostenibile

Concentrato sull'economia circolare-bassa impronta di carbone, componenti senza PFAS e riciclabili.

GARANZIA DI POTENZA

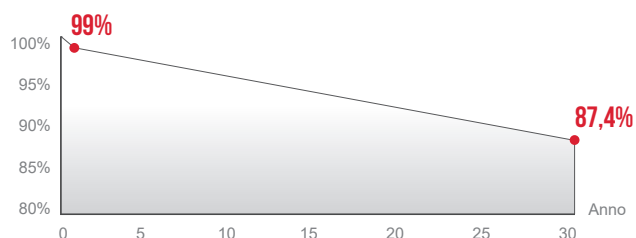

≤1% Degradazione al primo anno, ≤0,4% Degradazione annuale oltre 30 anni

SISTEMA DI MANAGEMENT AZIENDALE

- SA 8000: Norme OIL. Norme di responsabilità sociale
- ISO 9001: Sistema di gestione della qualità
- ISO 14001: Sistema di gestione ambientale
- ISO 45001: Sistema di gestione della salute e sicurezza sul lavoro
- ISO 50001: Sistema di gestione dell'energia
- ISO 27001: Sistema di gestione della sicurezza delle informazioni

CERTIFICAZIONE DI PRODOTTO

- IEC 61215, IEC 61730
- Resistenza estesa (IEC TS 63209)
- Corrosione da ammoniacca (IEC 62716)
- Corrosione da nebbia salina (IEC 61701)
- LeTID (IEC TS 63342)
- Polvere e sabbia (IEC 60068)



SolarPower Europe



Warranty partner

Munich RE 

DMxxxM10RT-B60HBT

Dati tecnici del modulo

Tipo di cella	Tipo N di monocristallino 120(6×20)
Dimensioni (mm)	1950×1134×30
Peso (kg)	26,8
Copertura anteriore	2mm di vetro rinforzato termicamente
Copertura posteriore	2mm di vetro rinforzato termicamente
Scatola di giunzione	3 diodi, IP68 secondo IEC 62790
Cavi	4mm ² /Verticale: 350mm(+)/250mm(-) Orizzontale: 1300mm(+)/1300mm(-) La lunghezza può essere personalizzata
Tipo di connettore	PV-ZH202B o MC4 (1000V) PV-ZH202B o MC4-EVO 2A (1500V)

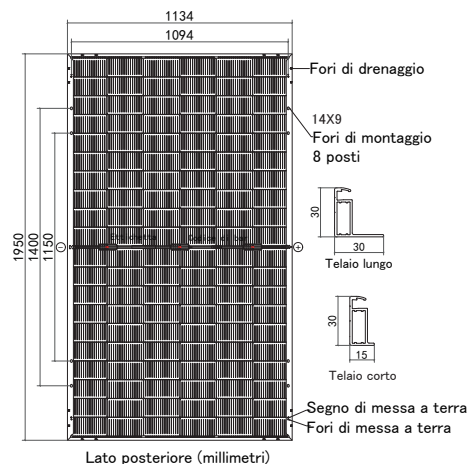

Specifiche elettriche¹

Tipo di modulo	DM490M10RT-B60HBT-U ⁴ DM490M10RT-B60HBT		DM495M10RT-B60HBT-U DM495M10RT-B60HBT		DM500M10RT-B60HBT-U DM500M10RT-B60HBT		DM505M10RT-B60HBT-U DM505M10RT-B60HBT		DM510M10RT-B60HBT-U DM510M10RT-B60HBT	
	STC ²	NMOT ³	STC	NMOT	STC	NMOT	STC	NMOT	STC	NMOT
Condizione di prova	STC ²	NMOT ³	STC	NMOT	STC	NMOT	STC	NMOT	STC	NMOT
Potenza massima (Pmax/W)	490	369	495	373	500	376	505	380	510	384
Corrente alla potenza massima (Imp/A)	13,16	10,58	13,23	10,64	13,30	10,69	13,36	10,74	13,42	10,79
Tensione alla potenza massima (Vmp/V)	37,26	34,84	37,46	35,03	37,66	35,22	37,86	35,40	38,06	35,59
Corrente di cortocircuito (Isc/A)	14,08	11,41	14,15	11,46	14,22	11,52	14,28	11,57	14,34	11,62
Tensione a circuito aperto (Voc/V)	44,30	41,71	44,50	41,90	44,70	42,09	44,90	42,28	45,10	42,47
Efficienza del modulo STC (%)	22,2		22,4		22,6		22,8		23,1	

¹ Misurazioni secondo IEC 60904-3, tolleranza di misurazione: Isc: ±4%, Voc: ±3%, incertezza di prova per Pmax: ±3%, Bifaccialità: 80%±5%

² STC (Standard Test Condition): Radiazione 1000W/m², temperatura del modulo 25°C, AM=1,5

³ NMOT: Radiazione 800W/m², temperatura ambiente 20°C, AM=1,5, velocità del vento 1m/s

⁴ "U" rappresenta il tipo di modulo doppio vetro applicato ad una tensione massima del sistema di 1000V DC

Specifiche elettriche¹ (BNPI²)

	490	495	500	505	510
Potenza di targa (W)	490	495	500	505	510
Potenza massima (Pmax/W)	542	547	553	558	564
Corrente alla potenza massima (Imp/A)	14,52	14,60	14,68	14,74	14,81
Tensione alla potenza massima (Vmp/V)	37,30	37,50	37,71	37,91	38,11
Corrente di cortocircuito (Isc/A)	15,49	15,57	15,64	15,71	15,78
Tensione a circuito aperto (Voc/V)	44,31	44,51	44,71	44,91	45,11

¹ Misurazioni secondo IEC 60904-3, tolleranza di misurazione: Isc: ±4%, Voc: ±3% Incertezza di prova per Pmax: ±3

² BNPI: Radiazione frontale 1000W/m², radiazione posteriore 135W/m², temperatura del modulo 25°C, AM=1,5

Caratteristiche di temperatura

Temperatura nominale di funzionamento del modulo (NMOT)	42±2°C
Coefficiente di temperatura di Pmax (%/°C)	-0,29
Coefficiente di temperatura del VOC (%/°C)	-0,25
Coefficiente di temperatura Isc (%/°C)	+0,048

Imballaggio

Container	40HQ
Dimensioni pallet (mm)	2000×1140×1250
Pezzi per pallet	36
Pezzi per Container	864

Condizioni operative

Temperatura di funzionamento (°C)	-40 A +85
Tensione massima del sistema (V)	1000/1500 DC (IEC)
Protezione contro le sovracorrenti (A)	30
Tolleranza di potenza in uscita (%)	0-3
Classe di protezione	Classe II
Carico massimo di prova, spinta/trazione (Pa)	Anteriore 5400 / Posteriore 2400
Carico massimo di progetto, spinta/trazione (Pa)	Anteriore 3600 / Posteriore 1600

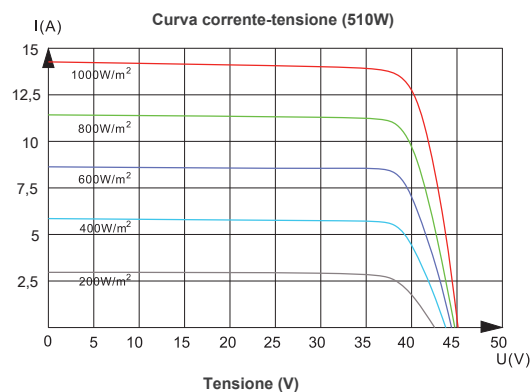

DMEGC
S O L A R

Hengdian Group DMEGC Magnetics Co.,Ltd.
Add: Hengdian Industrial Zone, Dongyang City Zhejiang Province, China 322118
Tel: 0086-579-8658-8826 E-mail: solar@dmeqc.com.cn Sito: www.dmeqcsolar.com

DMEGC Renewable Energy B.V.
Add: Industrieweg 2,2641 RM Pijnacker, The Netherlands.
Tel: +31 (0) 8 58200765 E-mail: contact@dmeqc.eu

Dichiarazione: Le istruzioni di installazione e le condizioni di garanzia devono essere seguite. In seguito al progresso tecnologico, i parametri del prodotto saranno adattati di conseguenza. Tutte le informazioni in questa scheda tecnica corrispondono alla norma EN 50380. Salvo modifiche ed errori. Documento: IT DS-M10RT-B60HBT-20240924.

©DMEGC 2024 – tutti i diritti riservati



HY-1000
Small Wind Turbine
User Manual

Copyright

Copyright © 2013 Guangzhou HY Energy Technology Co., Ltd.

All rights reserved.

Trademarks

All product, font and company names mentioned in this manual may be trademarks or registered trademarks of their respective companies.

Preface

Dear HYE owner:

Thank you for your purchase of HY wind turbine. We believe you will find it easy to install, moreover, we are confident you will experience years of dependable service from it.

Please make sure you have read the manual carefully before any assembly, installation or operation of HYE wind turbine, which is helpful for better & safe operation of HYE wind turbine. If any property loss due to the failure to follow the requirements and instructions of this manual, Guangzhou HY Energy Technology Co., Ltd (hereinafter, HYE) will not be liable for it.

This manual can help you better understand and properly use the HY series small wind turbine, but any contents of hardware will not be included. Concerning to the product configuration, please refer to the related contract (if any) or the distributor. Pictures in the manual are for reference only. If any difference from objects, please be subject to objects.

If you have any questions or comments, we would like to hear from you, and please call during working hours (Monday-Friday 9:00a.m. to 6:00 p.m. Beijing Time) if you need. Office number: 0086-20-36888000.

Sincerely,
HY Energy

	Serial number and Model number
	Serial number _____
	Model number _____

Safety Instructions

PLEASE READ THESE INSTRUCTIONS CAREFULLY BEFORE ASSEMBLING, INSTALLATING OR OPERATING OF YOUR HY WIND TURBINE.

1. Before HY series small wind turbine installation, you must know:

- 1) Do not install wind turbine on a windy day or dusty day with wind speed more than 8m/s.
- 2) Wearing wet gloves or clothes are forbidden.
- 3) Installing or maintaining wind turbine must be under professionals' guidance or contacting distributors.
- 4) Please Using cables as the standard mentioned in this user manual section 4 (wire size selection), cables too thin or with poor quality may lead to leakage or fires and line losses.
- 5) Non-professionals do not open the controller and inverter enclosure, any warranty claim will not be accepted if controller or inverter opened unauthorized.
- 6) Grounding device installation must be in accordance with application standard and installation instruction.
- 7) Battery wiring may splash spark, please makes sure without any inflammables near the work environment.
- 8) Please do not place the controller, inverter and battery at damp, rain, vibration, corrosion and strong electromagnetic interference environment, the places in direct sunlight, near heater or other heat sources are not allowed either.

2. Selection and installation requirements of controller and inverter:

- 1) Controller specification should be accordance with voltage, power, current of battery, solar panel battery set, and wind turbine and laden.
- 2) It is appropriated to install controller and battery in the same distribution box, and place it at a drafty room out of people reaching. Take some methods to prevent children from entering or stretching out hands into box.
- 3) Controller and battery installation should be accordance with relevant electrical equipment installation specification and comply with the operation specification constituted by manufacturer.
- 4) It is appropriated to use sealed lead acid battery for distribution box at inhabited room.

3. Wiring requirements:

- 1) The hardwired connect between components in system should be fixed and reliable. Do not use plugs or sockets.

- 2) Connect between system output terminal and external circuit should be fixed, or use socket for system output terminal.
- 3) Do not use two-way plug adapter for the connection of system's output terminal with external circuit.
- 4) Apart from the installation of the permanent circuit, any cables or wires that might be damaged due to outdoor exposure should be sheathed with conduit for protection.

4. Safety Precautions:

Operating personnel must full understand the safety precaution. Safety relies on our joined effort.

- 1) All operations must:
 - a. Follow instruction in this manual.
 - b. Operated by specialize workers.
 - c. Wrong operation might result in accident and injury to workers and equipments.
- 2) Operating personnel must master:
 - a. Equipment recognition
 - b. Correct equipment operation ability
 - c. Relevant safety knowledge

In this manual:



WARNING: Indicates risk of severe injury or death or possible severe damage to equipment - proceed with caution and follow instructions.



TIP: Indicates instruction or advice that may simplify or ease task or operation.



IMPORTANT: Indicates instruction or advice that is critical for correct assembly or operation. Damage to equipment may result if not heeded.

Content

Safety Instructions.....	4
Warranty	7
Exploded View & Parts List.....	9
1. Technical Specifications	13
2. Wind Turbine Assembly	14
2.1 Mounting Blades on The Hub	14
2.2 Connecting lead wires to Wind Generator.....	15
2.3 Mounting Turbines on The Pole	16
2.4 Hub/Blades and Generator Assembly	17
3 Tower Installation	19
3.1 Siting.....	19
3.2 Design Requirements	20
4. Wire Size Selection	24
5. Troubleshooting.....	25
5.1 Wind Turbine Troubleshooting.....	25
5.2 System Troubleshooting	27
6. Maintenance	29
Appendix	30

Warranty

Guangzhou HY Energy Technology Co., Ltd (HYE) provides 3 years limited warranty for wind turbine from the date of shipment, warranty covers all parts of wind turbine damaged within warranty period, free replacement part or complete wind turbine will only be provided after remote troubleshooting and analysis of the problem by HYE technicians, HYE hold the rights of providing the most appropriate solutions in terms of parts & complete turbine replacement and means of shipment.

Restrictions

Following defects will not be covered in this warranty:

1. Wind turbine has not been installed, operated, repaired, or maintained in accordance with instructions supplied by HYE; has been altered or modified unauthorized.
2. Damage caused by abnormal physical, thermal or electrical stress, negligence, misuse.
3. Damage caused by force majeure like lightning, hurricane force winds, flood, earthquake etc.
4. Damage caused by the use of any unauthorized controller, inverter or tower not provided or confirmed by HYE.

Warranty Claim Procedures

In order to get service under this warranty, customer must provide HYE with following information for analysis:

1. Serial number of wind turbine, running time, malfunction date.
2. Detailed description of the defects and corresponding test result has been done in accordance with the troubleshooting HYE provided.
3. HYE technician may ask for some extra testing in order to identify the defects so solutions could be provided promptly and precisely. HY series wind turbine users are liable to conduct these extra testing and provide referable test result.
4. Installation pictures (see details on the installation location and its surrounding).
5. Damaged machine pictures or videos.
6. HYE technician will provide final solution according to defect description and the test result of troubleshooting.

Customer is responsible for shipping the defect or damage part to HYE for repairing if needed, then HYE will repair or replace with new one for free and ship to owner on HYE cost, if no defected piece ship back to HYE but need replacement, HYE will provide the part for free but shipping expense will be at buyer side.

Consequential Losses

HYE is not responsible for any responsibility of consequential losses. Consequential losses mean:

1. Indirect, unexpected or special losses or damages;
2. Losses of margin or expected margin of products or any ways related with products

Exploded View & Parts List

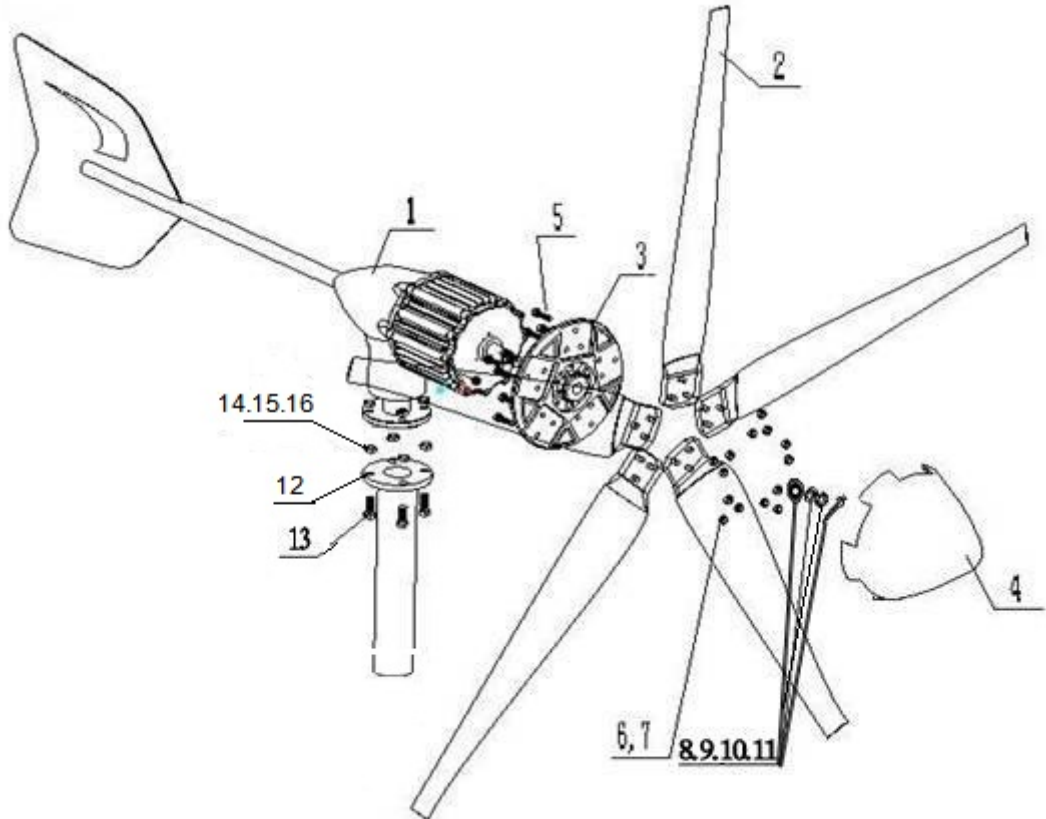

Flange connection wind turbine parts list			
Item	Description	Qty	Remarks
1	Tail vane	1	
2	Blades	5	
3	Hub	1	
4	Nosecone	1	
5	Hex bolt M8×40	15	For mounting blades on the hub
6	Flat washer Ø8	15	
7	Nylock nut M8	15	
8	Flat washer Ø16	1	For mounting hub on the rotor shaft
9	Spring washer Ø16	1	
10	Hex nut M16×1.5	1	
11	Cotter Ø4×28	1	
12	Lower flange	1	For connecting lower flange onto the top tower
13	Hex bolt M10×40	4	
14	Flat washer Ø10	4	
15	Spring washer Ø10	4	
16	Nut M10	4	

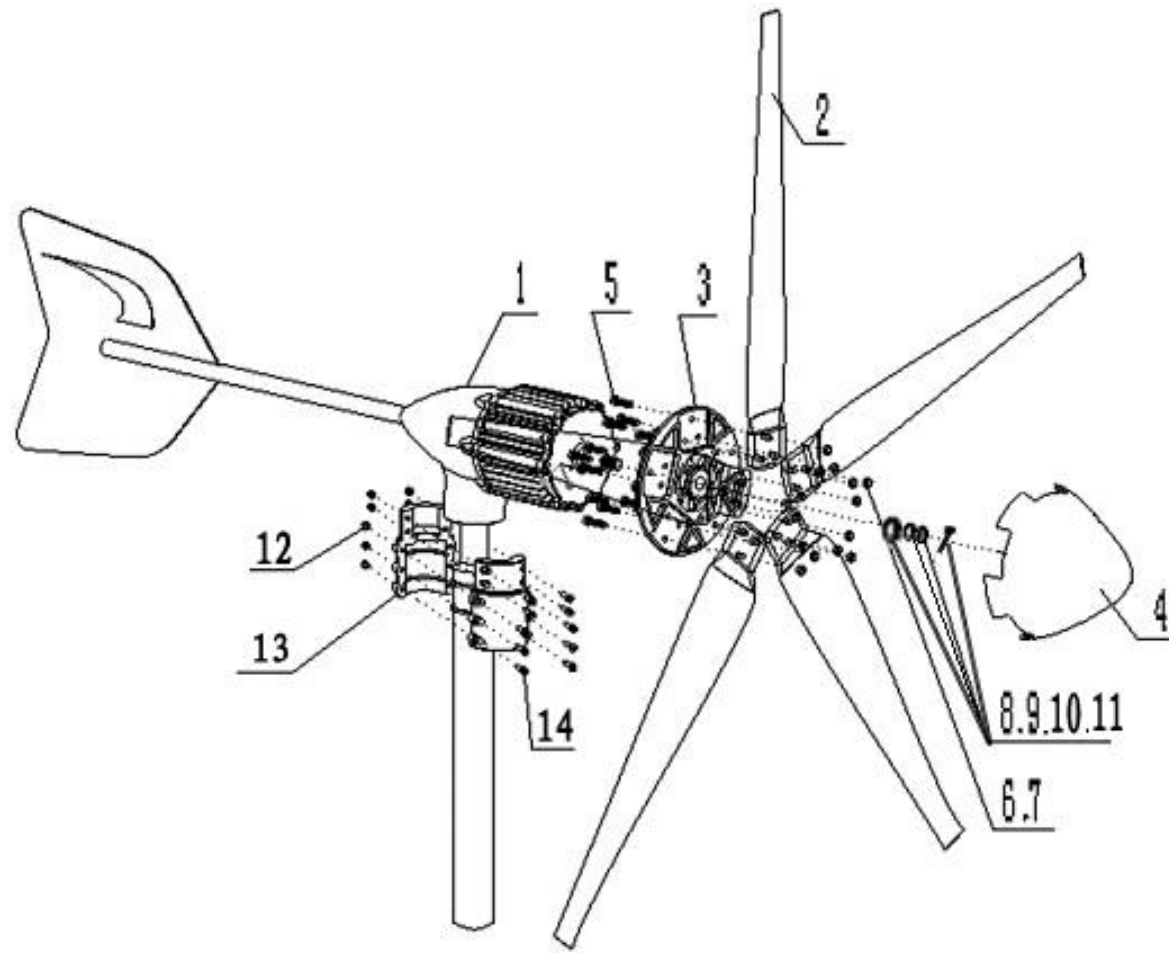

Bolt-on clamp connection wind turbine parts list			
Item	Component	Qty	Remarks
1	Tail vane	1	
2	Blades	5	
3	Hub	1	
4	Nosecone	1	
5	Hex bolt M8×40	15	For mounting blades on the hub
6	Flat washer Ø8	15	
7	Nylock nut M8	15	
8	Flat washer Ø16	1	For mounting hub on the rotor shaft
9	Spring washer Ø16	1	
10	Hex nut M16×1.5	1	
11	Cotter Ø4×28	1	
12	Locknut M6	10	For connecting bolt-on clamp
13	Bolt-on clamp	1	
14	Socket head screws M6×30	10	

1. Technical Specifications

Model	HY-1000		
Rated Power	1000W		
Max. Power	1200W		
Rated Voltage	24Vdc	48Vdc	110Vdc
Rated rotation speed	750rpm		
Start-up Wind Speed	2.0m/s		
Cut-in Wind Speed	2.5m/s		
Rated Wind Speed	12m/s		
Survival Wind Speed	50m/s		
Rotor Diameter	1.96m		
Blades Quantity	5		
Swept area	3.01m ²		
Noise Level	<20 dB (5m behind turbine @5m/s gusting)		
Generator Type	Three phase PMA		
Wind Turbine Type	Upwind		
Tower connection	Flange connection or bolt-on clamp		
Temperature	-40°C~60°C		
Strong wind protection mode	electromagnetic brake, blades aerodynamic brake		
Service life	15 years		
Net weight	28kg		
Gross weight	32kg		
Package size	146×53×27cm		

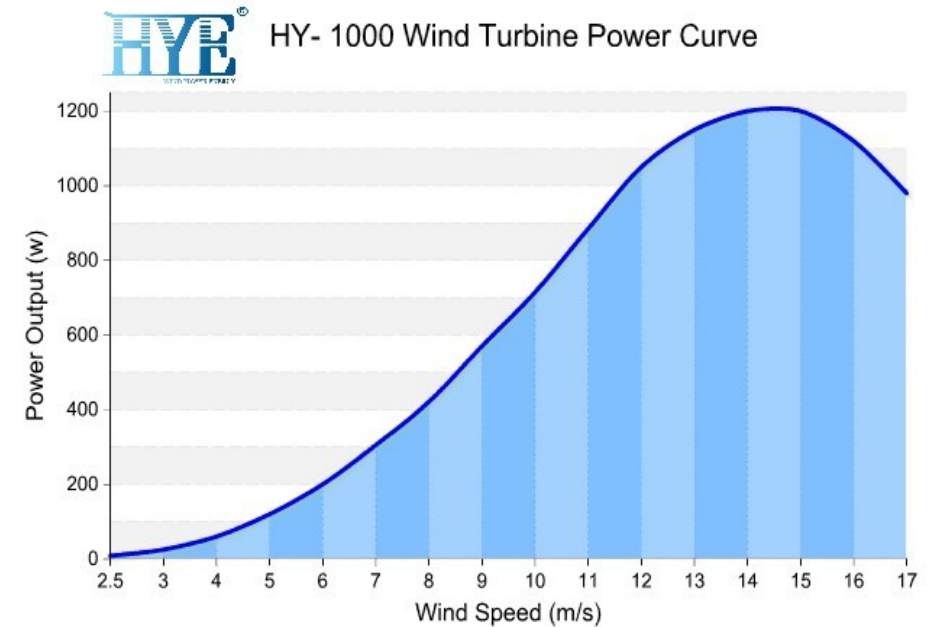

2. Wind Turbine Assembly

Installation on site is simple, mainly including mounting blades on the hub, securing the hub to the turbine body, installing the nosecone on the blade hub and mounting wind turbine on the pole.

Please install the whole turbine in accordance with the following instructions.

2.1 Mounting Blades on The Hub



① Check if all components are in good condition.

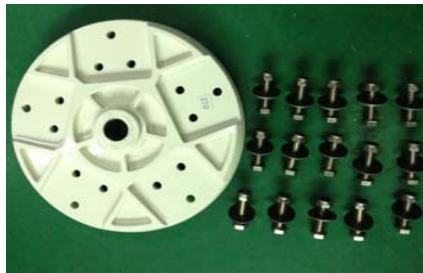

② The hub, washer, bolt and nylock nut



③ The blades.



④ Pass the hex bolts through from the back side of the hub.



⑤ Place blade, flat washer and nylock nut, and tighten the nut to 18N.m



⑥ Assembled.

2.2 Connecting lead wires to Wind Generator



① wind generator main body



② Unscrew cable cover.



③ Pass the wires through the cover.



④ Connect the three-phase lead wires into the terminals (make sure three phases are not short circuited)



⑤ Screw up the cable cover.



⑥ Screw up the waterproof cover.

2.3 Mounting Turbines on The Pole

2.3.1 Flange Connection



① Pass the cable through from the pole



② Connect the turbine to the pole by hex bolts.



③ Place flat washer, spring washer and nut, tighten the nut to 37N.m

2.3.2 Bolt-on clamp Connection



① The bolt-on clamp and accessories.



② Place rotating shaft on the upper part of the clamp.

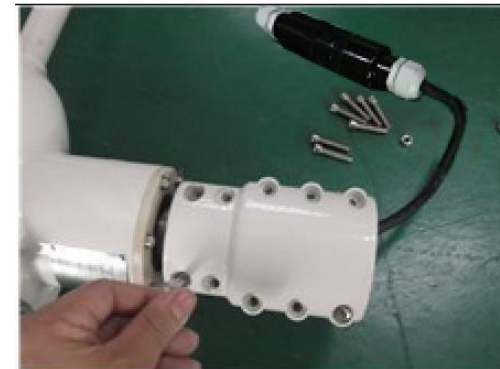

③ Assemble the clamps by socket head screws and locknuts, just leave the nuts not full tightened



④ Pass the lead wire through the pole.



⑤ The pole is inserted into lower part of the clamp.



⑥ tighten the nut to 9N.m

2.4 Hub/Blades and Generator Assembly

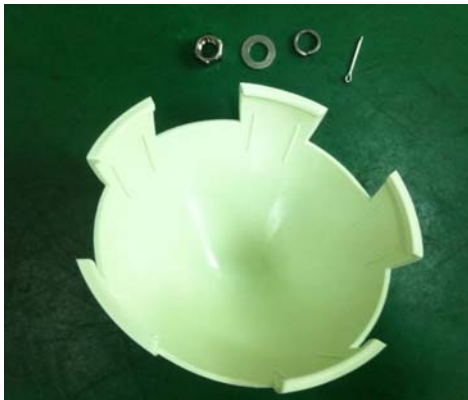

① The nosecone and accessories.



② Place the hub with blades onto the rotor shaft and “spin” it completely onto the turbine alternator shaft, then place in sequence of flat washer, spring washer and hex nut.



③ Fully tighten the nut to 154N.m



④ Insert the cotter into the shaft bore and separate the tails as shown.



⑤ Snap the nosecone into position over the outside edges of the blade hub. Make sure all five edges of the nosecone snap over the edge of the blade hub. After installation tug on the nosecone to make sure it is securely attached and turn the blades to make sure it is not rubbing against the front cover of the generator.



⑥ Completed assembly.

3 Tower Installation

3.1 Siting

An ideal location for wind generator is required with stable speed and direction of prevailing wind. Small changes in wind speed and direction can have a dramatic effect on power production. In general, the higher the tower, the greater the wind speed and ultimately power production are. Therefore, the site of your wind turbine should be carefully considered. Each installation is different and is often compromised among the tower height, distance from the battery bank, local zoning requirements and obstacles such as buildings and trees. Following requirements should be followed:

- The minimum recommended tower height is 20 ft (6 m) on open ground or 20 ft (6 m) above nearby obstructions (refer to following figure).

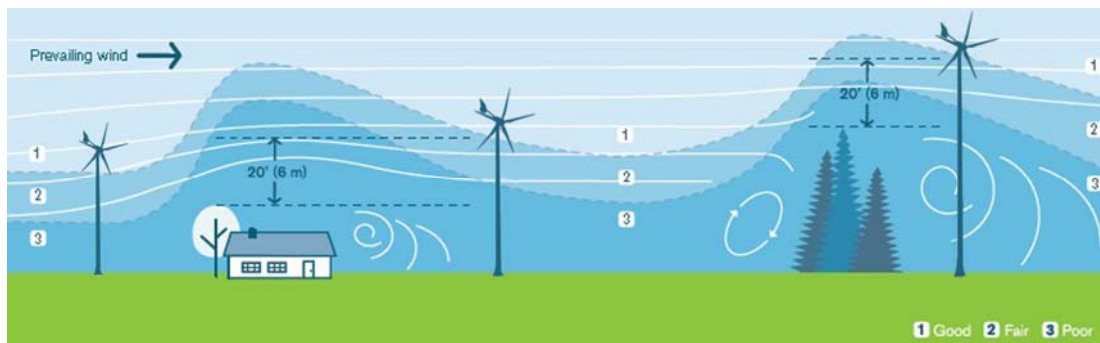

- Try to locate the wind turbine in the “cleanest” turbulent free air as possible. Turbulence will reduce the efficiency of wind turbine and may accelerate wear on rotating components.
- Try to locate the turbine without obstacles within 200m of installation center.

- The installation distance between two turbines should be 8-10 times of the rotor diameter.
- Installation site should be complied with local regulations.

Safety must be the primary concern when selecting the mounting location. Even if installing the wind turbine in a less ideal location, don't attempt to mount the turbine while blades are spinning. Safety has precedence over efficiency.



WARNING: Even if installing the turbine in a less windy location, the three-phase wires must be short circuited during installation to prevent the turbine from turning.

3.2 Design Requirements

The tower has a direct effect on the safety of the wind turbine. HYE offers some tower choices for HY series wind turbine. The following section provides a summary of the available towers.

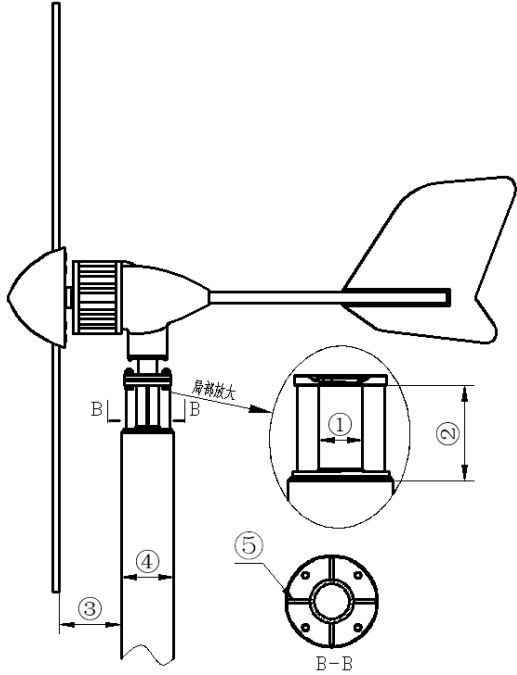
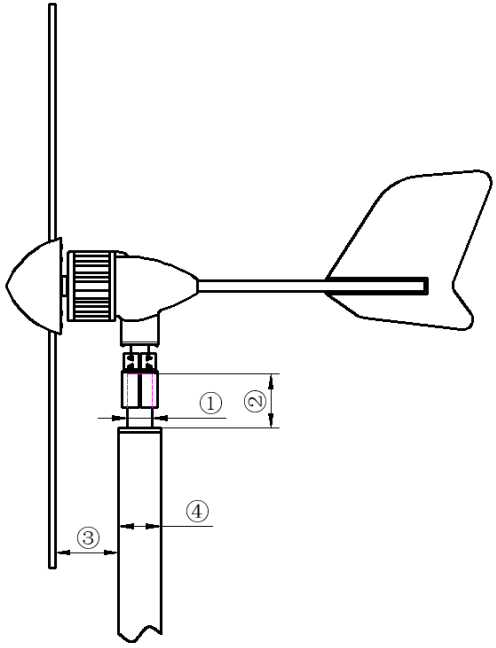
<p>Flange connection</p>		<p>Bolt-on clamp connection</p>	
<p>Dimension requirement:</p>		<p>Dimension requirement:</p>	
①	<p>ODΦ50×thickness 5mm seamless pipe</p>	①	<p>ODΦ60×thickness 5mm seamless pipe</p>
②	<p>100 ≤Length“L” (pipe length) ≤ 150</p>	②	<p>120 ≤Length“L” (tube length) ≤ 160</p>
③	<p>130 ≤Distance“ L” (blade tip to pole)</p>	③	<p>130 ≤Distance“ L” (blade tip to pole)</p>
④	<p>Pole Diameter “D” Self support—same diameter: Φ100 ≤ D ≤Φ150 Self support—taper shape: Φ100 ≤ D (upper diameter) ≤Φ150</p>	④	<p>Pole Diameter “D” Self support—same diameter: Φ100 ≤ D ≤Φ150 Self support—taper shape: Φ100 ≤ D (upper diameter) ≤Φ150</p>
⑤	<p>Reinforcing rib 4 pcs</p>	<p>Unit:mm</p>	

Special installation 1: pitched rooftop

Explanations:

1. This installation is workable for pitched rooftop house.
2. This wall-mounted installation is used expansion bolt to fix the supporting structure.
3. The wall should be concrete or solid wall.
4. Try to install the turbine in an upwind direction position.
5. The lowest point of the blade should be above the rooftop.

Dimension requirement:

①	$1.2\text{ m} \leq \text{distance from rotor centre to top of rooftop}$ "L" $\leq 2.0\text{ m}$
②	$1.5\text{ m} \leq \text{distance from rotor centre to the first supporting point}$ "L" $\leq 2.5\text{ m}$
③	$1.0\text{ m} \leq \text{distance between the two supporting points}$ "L" $\leq 1.5\text{ m}$
④	Pole diameter \geq Outer Diameter $\Phi 60\text{mm} \times$ thickness 6.0mm seamless pole

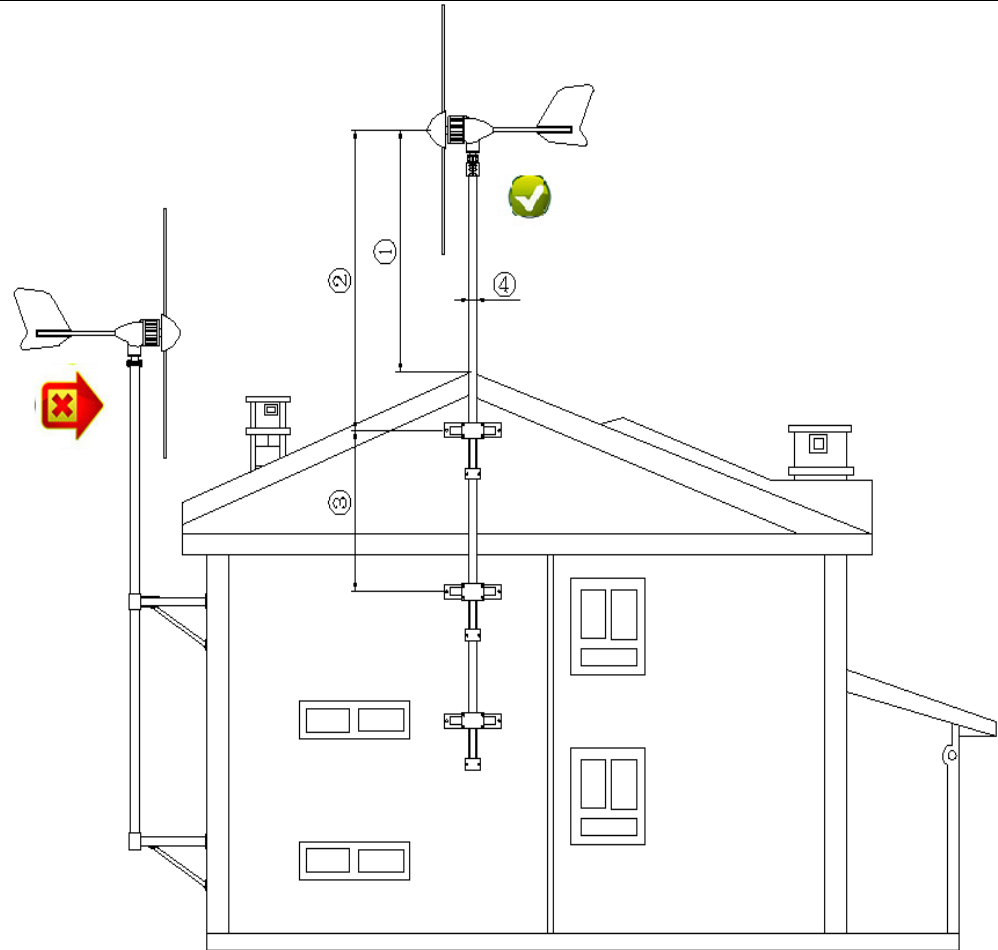

Special installation 2: flat roof top

Explanations:

- 1.This installation is workable for flat roof top.
- 2.The wall or ground of rooftop should be concrete or solid wall.
- 3.These two installations could be both used expansion bolt to fix the supporting structure.

Dimension requirement:

①	Distance from rotor centre to roof top ≥ 4 m
②	Supporting point should be 1.2 times of the rotor diameter
③	Distance from blade tip to pole ≥ 130 mm
④	$\Phi 76\text{mm} \leq \text{Outer diameter} \leq \Phi 150$ mm
⑤	Angle steel or guyed fastening structure
⑦	distance from rotor centre to roof top $\geq 1.5\text{m}$
⑧	$1.5\text{m} \leq \text{distance from rotor centre to the first supporting point} \leq 2.0$ m
⑨	$1.2\text{m} \leq \text{distance between the two supporting points} \leq 2.0\text{m}$
⑩	Pole diameter \geq Outer Diameter $\Phi 60\text{mm} \times$ thickness 6.0mm seamless pole

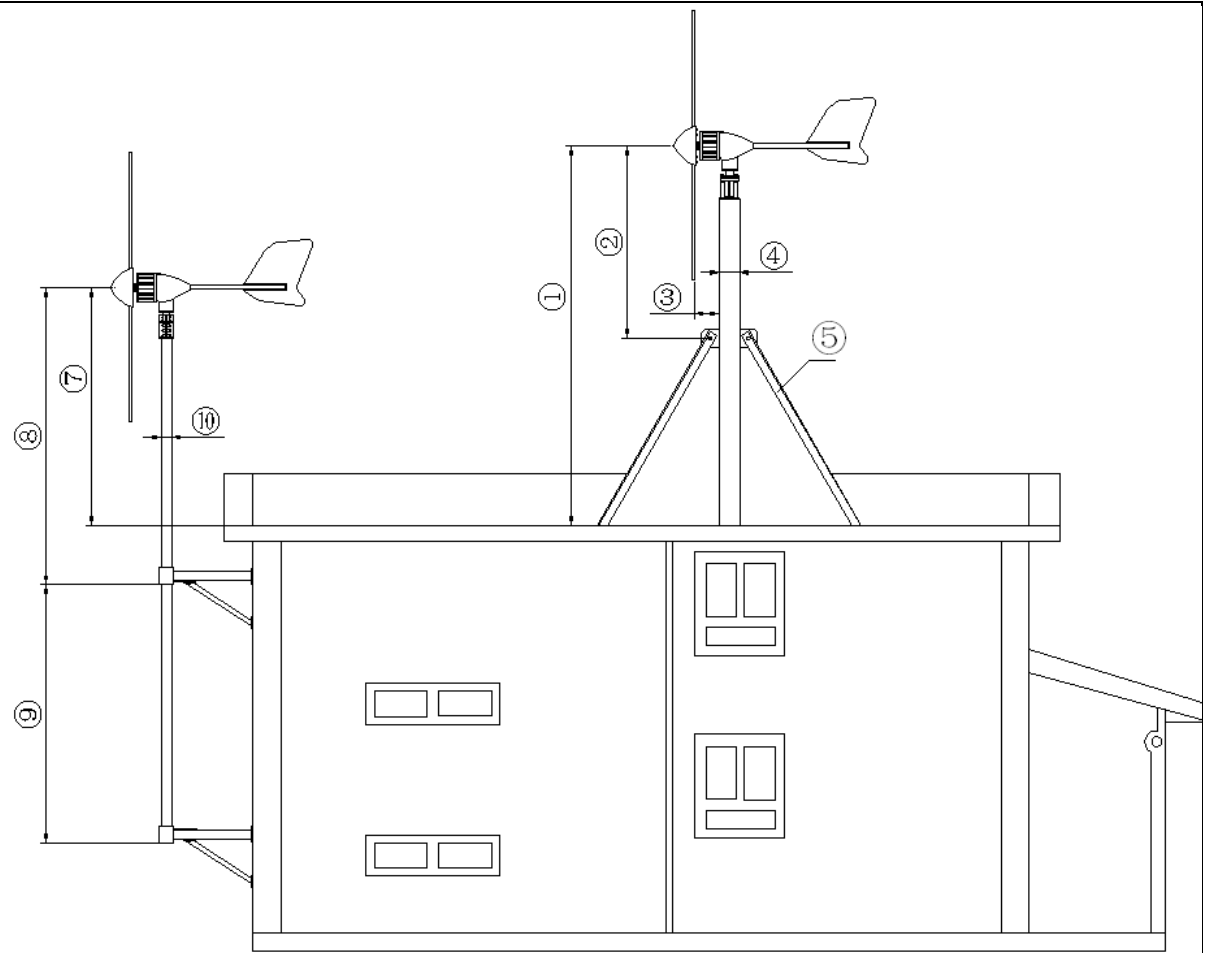

4. Wire Size Selection

All electrical systems lose energy due to resistance in conductors: the wires.

- The larger the wire is, the less resistance and the loss are
- Resistance losses will also increase with increasing current; therefore, if your installation is at a high wind site, it may be worthwhile to go with a larger size wire to lower the loss and enhance the output of wind turbine.
- Conversely, in low wind sites it may not be cost effective to increase the wire size since power production will be comparatively lower.

To determine the wire size, measuring the distance from the batteries to wind turbine is necessary, be sure to include height of the tower. Refer to the appropriate chart for your system voltage and select the wire size. The following wire sizes provide maximum annual energy losses of 3% for most sites.

HY-1000/24V system

Distance from wind generator to controller	0—10m	11—20m	21—30m	31—40m	41—50m	51—60m	61—70m	71—90m
AWG/Metric Wire Size mm ²	10/5mm ²	6/13 mm ²	4/21 mm ²	3/26 mm ²	2/33 mm ²	1/42 mm ²	1/42 mm ²	0/53 mm ²

HY-1000/48V system

Distance from wind generator to controller	0—10m	11—20m	21—30m	31—40m	41—50m	51—60m	61—70m	70—100m
AWG/Metric Wire Size mm ²	11/4 mm ²	11/4 mm ²	10/5 mm ²	9/6 mm ²	8/8 mm ²	7/10 mm ²	6/13 mm ²	5/16 mm ²

HY-1000/110V system

Distance from wind generator to controller	0—10m	11—20m	21—30m	31—40m	41—50m	51—70m	71—90m	91—110m
AWG/Metric Wire Size mm ²	11/4 mm ²	11/4 mm ²	11/4 mm ²	11/4 mm ²	11/4 mm ²	11/4 mm ²	11/4 mm ²	11/4 mm ²

5. Troubleshooting

5.1 Wind Turbine Troubleshooting

5.1.1 Wind Turbine Vibration

Wind turbine vibration is mainly caused by the following factors:

- 1) The blades mounting bolts get loose and need to be tightened;
- 2) The surface of blades gets frozen and needs to be removed;
- 3) The blades have been distorted, defected and need to be replaced.
- 4) The tower is not strong enough or guy rope gets loose, and needs to be reinforced or tightened;
- 5) The wind turbine operates lacking phase, need to check if the three-phase output voltage is balanced or not by testing with multimeter.



IMPORTANT: Turbine operation should be stopped as soon as abnormal vibration happened till problems solved to avoid personnel or machine damaged.

5.1.2 Wind Turbine Insensitive to Adjust Rotor Direction

- 1) HYE wind turbine mainly adopts tail yawing to adjust the blades direction, if it is not sensitive to adjust blades direction, reasons may be: the turbine alternator shaft is damaged, or the tower is out of plumb.
- 2) The tower flange is not matching with the flange on turbine, which cause the interference to adjust the wind turbine facing direction. ① check if the flange is provided by HYE or in accordance with HYE flange drawing; ② check if the flange on turbine is loose, and if the axis of rotation fall into the tower.
- 3) The wind turbine is in a swinging or seeking status: ① the wind turbulence caused by natural factors is normal; ② improperly located, if turbulence is caused by buildings, wind turbine should re-locate another good position.

5.1.3 Rotation speed Dramatically Decreases

Wind turbine rotation speed dramatically decreases under heavy wind condition, which can be mainly divided into normal deceleration and abnormal deceleration:

- 1) Turbine normal deceleration is due to wind turbine over-speed protection, for example, dump load, electromagnetic braking and blades aerodynamic braking. These are regular protection ways to protect the wind turbine and the whole system in high wind.
- 2) Turbine abnormal deceleration is mainly due to friction between rotor and stator, bearing damaged, generator burned, blades deformation or damaged, turbine or pole shake heavily, in case of these situations, please disconnect wind turbine from controller and put three-phase in short circuit mode, then contact supplier to solve the problem.

5.1.4 Generator Abnormal AC Output

- 1) Generator abnormal which is due to long connecting wire or small wire size which results in high pressure drop, therefore, selection of wire size should refer to 6.5 regulations and requirements.
- 2) Check if the wind turbine three-phase output performs well, check the voltage of each two of the output phases are balanced.
- 3) Generator three-phase output voltage is imbalanced. Voltage unbalanced rate shall not exceed 10% (same wind speed or rotational speed) in accordance with related national standards, if exceeded, the generator fails, please contact supplier to solve the problem.
- 4) Generator has no output voltage under heavy wind condition, check whether generator is under short-circuit mode or not (reference: 5.2) and three-phase resistance values is balanced or not (uncharged operation), if imbalanced, the generator fails, please contact supplier to solve problems.



WARNING: Never check the wind turbine while the blades are spinning or on a windy day.

5.1.5 Abnormal Noise

- 1) Friction between rotor and stator, or bearing damaged - please contact supplier to solve the problem.
- 2) Check if wind turbine is rotating abnormally, or noise generated by self-vibration.(reference:5.1.1)

5.2 System Troubleshooting

5.2.1 Off-grid wind and solar hybrid system

5.2.1.1 Solar Output Voltage Too Low or No Output

- 1) Check whether solar panel lead is short circuit, circuit break, open circuit or not.
- 2) Check whether solar panel is damaged or accumulated too much dust, etc.

5.2.1.2 Abnormal charging

Wind turbine does not charge battery is mainly caused by:

- 1) Wind speed is too low to reach cut in point. For the off-grid system, when the DC input voltage is higher than battery voltage, it starts to charge the battery, otherwise it will be no charging.
- 2) Wind speed is high, but Wind Turbine Does Not Charge Battery
 - a. The wind turbine DC output voltage is lower than battery's: ①check whether the output of wind turbine is normal (reference: 5.1.4);
②check whether the rotation speed of wind turbine is normal.
 - b. The wind turbine DC output voltage is higher than battery's: ① check whether the system wiring is correct and each terminal wiring is well connected; ② check whether the controller could rectify power normally. (refer to controller user manual)
 - c. The type of battery and controller does not match, replace the battery (lead-acid or AGM gel battery is recommended);
 - d. The battery reached saturation, so wind turbine is on braking mode because of overcharge protection function of the controller

5.2.1.3 Abnormal output

- 1) Control mode of controller is set incorrectly or damaged and need a replacement. (Reference: controller user manual)
- 2) Battery is under over-discharge state, check the battery voltage and need to exclude the reason of low battery voltage. (Reference: 5.2.1.2)

5.2.2 Grid-tied Wind Turbine System

5.2.2.1 No power feed into grid

- 1) wind speed is too low, wind turbine still haven't reach it's cut-in wind speed, so no current generated in less than 2.5m/s wind speed.
- 2) Wind speed is too high, wind turbine output voltage reach the over-voltage point, controller short-circuit braking system protect the wind turbine and the whole system, the system will restore automatically when the wind speed decrease.
- 3) The controller short-circuit brake was switched on manually, it will restore when switch on the short-circuit switch manually.
- 4) On-grid inverter is in disconnected from grid or damaged. (Reference: inverter user manual)
- 5) Check whether controller DC output voltage is normal. Troubleshooting: ①wind turbine troubleshooting (Reference:5.1.4); ② check whether the controller is damaged (Reference: controller user manual).
- 6) Check whether the system wiring is correct, note that electrodes should be connected in a right way, the system will restore by automatically after reconnected.
- 7) The wind turbine output characteristics and inverter does not match; solutions: ① replace wind turbine; ② replace on-grid inverter; ③ adjust the internal parameters (power curve and power factor setting)of the on-grid inverter.
- 8) Check whether the wiring is loose, poor contact and the state-grid is stable.

5.2.2.2 Low charging power

- 1) Wind turbine output voltage is low; main reasons: ① low wind speed; ②wind turbine troubleshooting (Reference: 5.1.4).
- 2) The wind turbine output characteristics and inverter does not match; solutions: ① replace wind turbine; ②replace the on-grid inverter; ③ adjust the internal parameters of on-grid inverter.

6. Maintenance

Although your high reliability of HY wind turbine has been designed to run for 15 years without any maintenance, reliability and performance will be enhanced if you periodically inspect your system.



IMPORTANT: It is suggested that putting down the pole and making wind turbine short circuit before some extremely bad weather, such as typhoon, in case of some unpredictable accidents happen.

The following situations need regular maintenance:

No.	Maintenance item	After storm	Every six months	Every one year	Every two years	Every five years
1	check blades for chips or nicks	√	√			
2	Check the blade bolts and the hub nut for tight	√	√			
3	Check nosecone for cracks and proper fit	√	√			
4	Wash off any built-up dirt or debris from the blades	√	√			
5	Check all electrical connections to make sure they are tight and free from corrosion.	√	√			
6	Replace blades					√
7	Replace battery					√
Remark: "√" indicates maintenance.						

Appendix I

Definition of 50m/s survival wind speed of HYE wind turbine

HYE wind turbine is strict in accordance with following standards:

GB/T 10760.1 Generator of Off-grid Wind Turbine Generator System Part 1:Technology condition

GB/T 13981-2009 Design General Requirements for Small Wind Turbine Generator System

GB 17646 Safety of Small Wind Turbine Generator System

GB/T 19068.1 Off-grid Wind turbine Generator Systems Part 1:Technology condition

JB/T 10399-2004 Rotor Blades for Off-grid Wind Turbine Generator System

JB/T 10402.1-2004 Yaw System of Wind turbine Generator Systems Part 1:Technology condition

JB/T 10403-2004 Tower for Off-grid Wind Turbine Generator System

JB/T 10405—2004 Technical Condition for Foundation and Linkage of Off-grid Wind Turbine Generator System

NY/T 1137-2006 Installation Specification of Small Wind Turbine Generator System

Our HYE wind turbine belongs to Class III in accordance with wind turbine international grade, please refer to following chart,

级 别	I	II	III	IV
\bar{v}_E m/s	50	42.5	37.5	30
\bar{v}_N m/s	10	8.5	7.5	6

In order to be compatible with extreme load of international safety standard, while calculation of the load, the \bar{v}_E and all of wind speed which is calculated by \bar{v}_E should be reduced by 7%.

As we all know, the huge wind, storm or hurricane usually does not last for a long time, assuming a huge wind occurred once in 50 years, the average maximum wind speed within 5 seconds at hub height is represented by v_E , it is calculated by \bar{v}_E multiply coefficient 1.4, that is $v_E=1.4\bar{v}_E$

From above explanation, the survival wind speed of Class III wind turbine is:

$$v_E=1.4\bar{v}_E-1.4\bar{v}_E*7\%=1.4*37.5-1.4*37.5*7\%=52.5-3.68=48.82\text{m/s} (<50\text{m/s})$$

So this is why the survival wind speed of HYE wind turbine is 50m/s.

Generally speaking, the safety and operation of wind turbine is closely related with matching components, correct pole installation, correct system cable connection, these three factors we could control and we have to do them well, However, wind turbines are installed outdoors, it is also close with natural environment situations, in case of force majeure factors, such as storm, earthquake, or attacked by hailstone, dust, wind turbines may be damaged.

Appendix II (Source: National Weather Service Portland, <http://weather.gov/portland>)

Estimating Wind Speeds with Visual Clues			
Beaufort number	Description	Speed	Visual Clues and Damage Effects
0	Calm	Calm	Calm wind. Smoke rises vertically with little if any drift.
1	Light Air	1 to 3 mph	Direction of wind shown by smoke drift, not by wind vanes. Little if any movement with flags. Wind barely moves tree leaves.
2	Light Breeze	4 to 7 mph	Wind felt on face. Leaves rustle and small twigs move. Ordinary wind vanes move.
3	Gentle Breeze	8 to 12 mph	Leaves and small twigs in constant motion. Wind blows up dry leaves from the ground. Flags are extended out.
4	Moderate Breeze	13 to 18 mph	Wind moves small branches. Wind raises dust and loose paper from the ground and drives them along.
5	Fresh Breeze	19 to 24 mph	Large branches and small trees in leaf begin to sway. Crested wavelets form on inland lakes and large rivers.
6	Strong Breeze	25 to 31 mph	Large branches in continuous motion. Whistling sounds heard in overhead or nearby power and telephone lines. Umbrellas used with difficulty.
7	Near Gale	32 to 38 mph	Whole trees in motion. Inconvenience felt when walking against the wind.
8	Gale	39 to 46 mph	Wind breaks twigs and small branches. Wind generally impedes walking.
9	Strong Gale	47 to 54 mph	Structural damage occurs, such as chimney covers, roofing tiles blown off, and television antennas damaged. Ground is littered with many small twigs and broken branches.
10	Whole Gale	55 to 63 mph	Considerable structural damage occurs, especially on roofs. Small trees may be blown over and uprooted.
11	Storm Force	64 to 75 mph	Widespread damage occurs. Larger trees blown over and uprooted.
12	Hurricane Force	over 75 mph	Severe and extensive damage. Roofs can be peeled off. Windows broken. Trees uprooted. RVs and small mobile homes overturned. Moving automobiles can be pushed off the roadways.

Wind & Solar Hybrid Controller





User Manuel

Ver. 2.0-20130

Thank you for purchasing our product(s). The manual is provided to people who need to install and operate the controller. Read this manual before any work with controller and keep it carefully. The contents of this manual will be periodically updated or revised if necessary. However discrepancies cannot be excluded. Please refer to the actual product(s).

Symbols

The following symbols are used throughout this manual to indicate potentially dangerous conditions or mark important safety instructions.

-  **WARNING:** Indicates a potentially dangerous condition. Use extreme caution when performing this task.
-  **INDICATION:** Indicates a procedure or function that is important.
-  **NOTE:** Indicates a specific description for content.

General Safety Information

- Before receive the product, check it carefully. Make sure whether the product is damaged during transport. If it is damaged, contact the shipping company or our company immediately.
- All installation and electrical work must only be performed by professional personnel.
- Without any professional guidance, do not disassemble or attempt to repair the controller.
- Do not use the controller without batteries.
- Do not cut off the connection of controller and batteries when controller is working normally.
- Keep children away from controller.
- Do not allow water to enter the controller.
- Confirm that power connections are tightened to avoid excessive heating from a loose connection. Make sure cables are suitable for system.

1 Product Introduction

This kind of wind and solar hybrid controller is special design for off-grid wind solar hybrid generation system. Appearance is elegant, operations are easy. It also makes the course wind generator and solar panels charge to batteries safely and efficiently.

1.1 Functions and Features

1.1.1 Basic Functions

- **Wind Turbine and Load Adaptive Impedance Matching, maximize energy utilization.**
There is internal resistance in Wind generators, batteries and loads. According to impedance matching principle, only when input impedance equals to output impedance, power utilization is maximal, get the maximum power.
- **Protect wind generator from over-revolution speed, over-voltage and over-current**
Max revolution speed, max voltage and max current of wind generator could be set. Once the actual revolution speed, voltage or current over the set ones, PWM intelligent unloading will start automatically. That protect wind generator.
- **Intelligent limiting of batteries max current**
Batteries maximum capacity could be set through this controller. According to the set maximum capacity, controller could calculate the maximum charging current. Then batteries will be protected.
- **Function of manual brake**
- **Wind charging manual switch**
On the controller you can manually set whether using wind charge to battery.
- **Solar charging manual switch**
On the controller you can manually set whether using solar charge to battery.
- **BOOST and BUCK function in one**
(If do not buy Boost & Buck Wind Solar Controller, there is no this function)
Once wind generator voltage is lower than battery voltage, controller starts boost module automatically. Wind generator voltage is increased to the charging voltage, and it is boost charging. When wind generator voltage is higher than battery voltage, in order to acquire max power, buck module of controller will be started, the generator is buck charging.
Loads lower the revolution speed of wind generator, when it is breeze. That decreases the output power of wind generator. Through max current tracking (MCT) and max power point tracking (MPPT), output of wind generator is stabilized at the max balance of wind energy utilization. Combine with boost and buck function, wind energy utilization is increased.

- **BOOST function**
(If do not buy Boost Wind Solar Controller, there is no this function)
Once wind generator voltage is lower than battery voltage, controller starts boost module automatically to charge to battery.
- **BUCK function**
(If do not buy Buck Wind Solar Controller, there is no this function)
- Once wind generator voltage is higher than battery voltage, controller starts buck module automatically to charge to battery.

1.1.2 Optional Function

The following functions are available for purchase.

- **USB function**
Record controller's working data by USB stick. Users can analyze the data on PC.
- **RS232 interface**
By serial interface communication, you could monitor the whole system, storage and analyze data.
Program could be upgraded by serial interface.
Connect PC and controller by serial interface. You could set the parameters on PC and controller simultaneously.
Software is free, easy to operate and no need to be installed.
- **RS485 interface**
- **Anemometer function**
Wind speed could be displayed on LCD, easy to observe.

1.2 Appearance

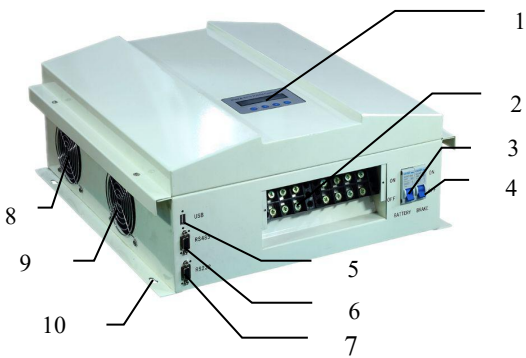

Figure1-1 Appearance description

Item	Name	Description
1	LCD display panel	A friendly human-computer interaction interface. Running data and configuration parameters are displayed in the LCD screen. Parameters could be set by keys on the panel.
2	Terminal block	Connect wind generator, pv panel, battery and load.
3	Battery switch	Disconnect battery current safely
4	Wind brake switch	Turn on (ON) or turn off (OFF) wind braking
5	USB	Storage data (If don't purchase, no USB interface)
6	RS485 interface	Communication interface (If don't purchase, no this interface)
7	RS232 interface	Communication interface (If don't purchase, no this interface)
8	Resistance cooling fan	This fan rotates when wind generator braking ,cooling the resistances
9	System cooling fan	This fan rotates when charging current is too high, cooling the system
10	Mounting holes	Install controller

1.3 Dimensions

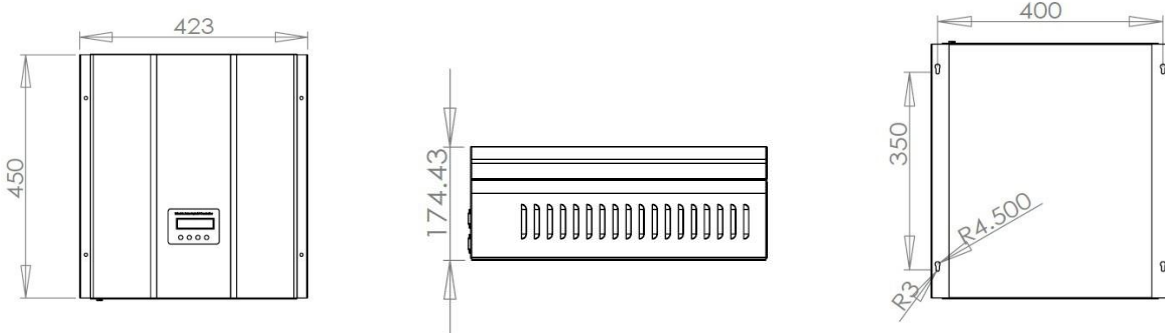

Figure1-2 Dimensions of controller

2 Installation and Electrical Connection

2.1 Installation

2.1.1 Mounting Notes

- ⚠ Read through this entire section first before beginning installation.
- ⚠ All mounting work must only be performed by professional personnel.
- ⚠ Disconnect all sources of power to the controller before installing or adjusting.
- ⚠ Do not allow water and snows enter the controller.
- ⚠ Install in locations where is dustless, airy and avoid direct sunlight.
- ⚠ If install controller in a cabinet, make sure there is enough space for controller heat-dissipating.
- ⚠ Keep controller away from corrosive gas and intense electromagnetic interference.
- ⚠ Locate the product in where easy to install, electrical connection and service.

2.1.2 Mounting Steps

1. Choose mounting location.(Please refer to installation notes)
2. Check for clearance around the location; make sure there is enough space for connecting cables.
3. Prepare tools for installation.
4. Place the controller to the mounting location.
5. Check that the controller is securely mounted.

2.2 Electrical Connection

2.2.1 Overview of Electrical Connection

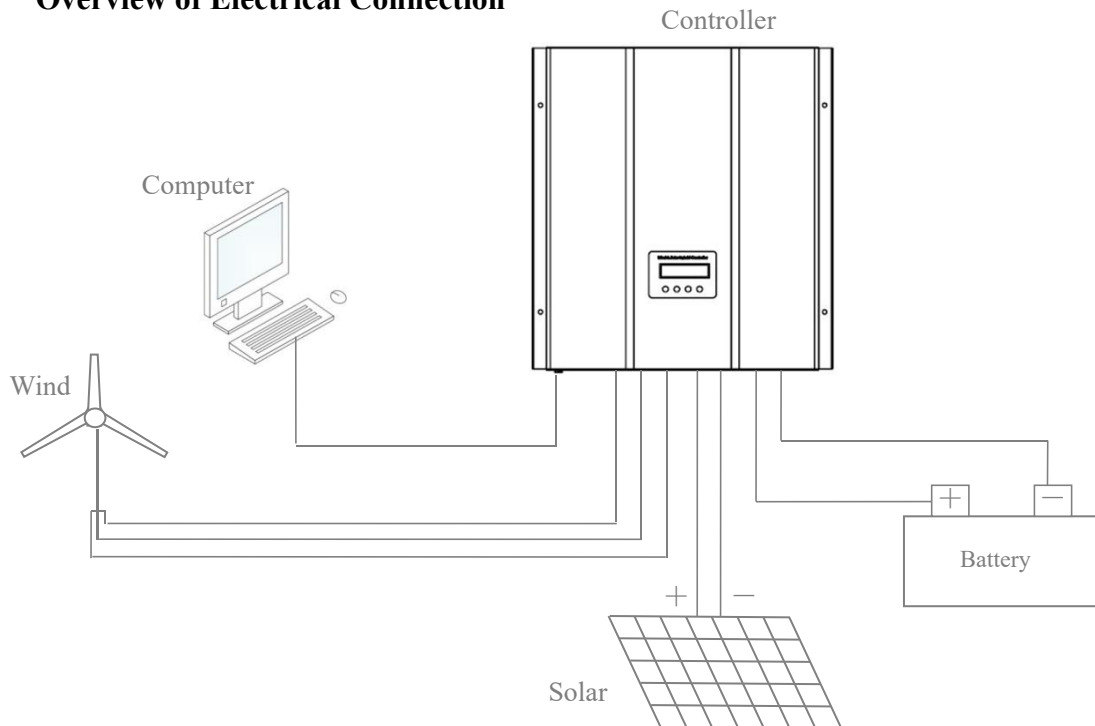

Figure2-1 Overview of electrical connection

2.2.2 Wiring Notes

- ⚠ Improper operation during the wiring process can cause fatal injury to the operator or unrecoverable controller damage.
- ⚠ Only qualified personnel can perform the wiring work.
- ⚠ All cables must be undamaged, properly insulated and adequately dimensioned.
- ⚠ Make sure that all cables are firmly attached. Unsecured cables create loose and resistive connections which may lead to excessive heating and /or fire.
- ⚠ For mobile applications, be sure to secure all wiring, avoid loose connections.

2.2.3 Wiring Steps (Follow the bellow suggestions and steps to connect)

2.2.3.1 Battery Wiring

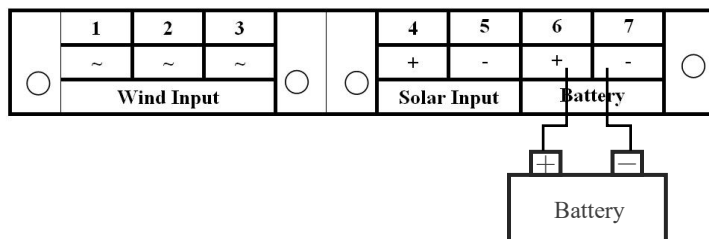

Figure2-2 Battery wiring

Connect battery positive(+) and negative(-) wires to controller as shown in figure2-2.

- ⚠ Be careful of avoiding short circuit when wiring the battery.
- ⚠ Before wiring the battery, keep the battery switch of controller (BATTERY) on OFF, Do not switch it to ON until you confirm the wiring is correct and safe.
- 🔒 Although controller has the protection of battery anti-reverse, but anti-connecting of positive (+) and negative(-) is forbidden.

2.2.3.2 Solar Wiring

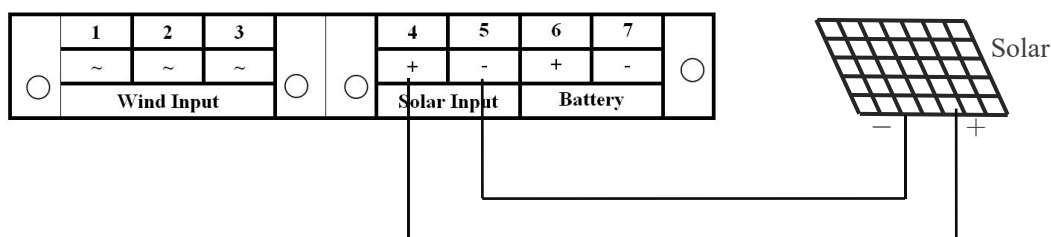

Figure2-3 Solar wiring

Connect solar positive(+) and negative(-) wires to controller as shown in figure2-3.

- ⚠ The solar PV array may produce high voltages in sunlight. Be careful of electric shock when wiring.
- 🔒 Although controller has the protection of solar anti-reverse, but anti-connecting of positive (+) and negative(-) is forbidden.

2.2.3.3 Wind Generator Wiring

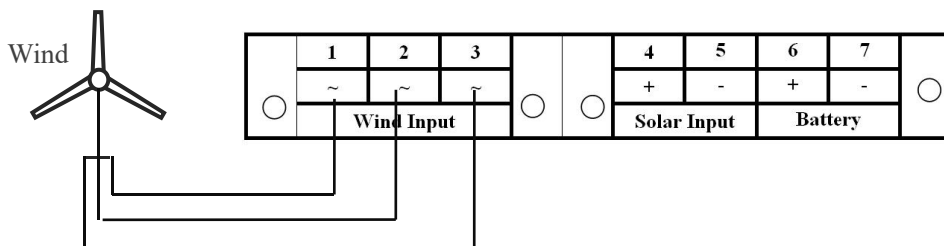

Figure2-4 Wind generator wiring

Connect wind generator wires to controller as shown in figure2-4.

- ⚠ The wind generator could produce high voltages. Be careful of electric shock.
- ⚠ When it is breeze or windless, connection of wind generator and controller would be safer and better. Only when controller is in the state of start-up, high-speed rotate wind generator could be connected.

2.2.4 Confirm Wiring

Double-check the wiring. Make sure each connection is correct. Secure no loose and resistive connections.

3 Operation

3.1 Description of Buttons

Buttons	Description
Menu	Enter into sub-screen or confirm the command.
◀	Switch between sibling menu or decrease the setting value.(Press more than two seconds change the setting value quickly)
▶	Switch between sibling menu or increase the setting value.(Press more than two seconds change the setting value quickly)
Esc	Return to parent screen or cancel the command.

3.2 Overview of LCD Menu

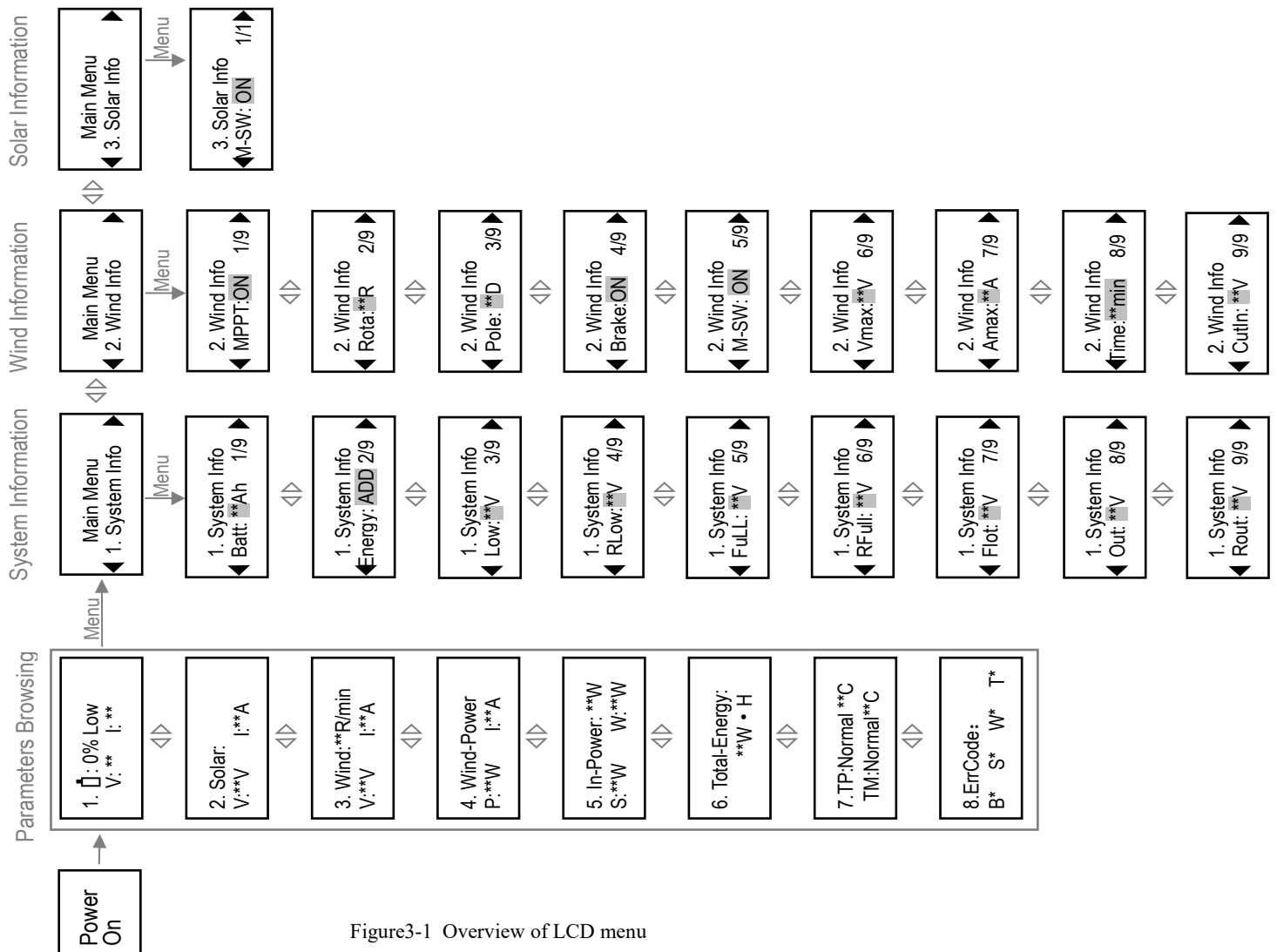

Figure3-1 Overview of LCD menu

The grey shaded parameters could be set manually by users.

Parameter setting steps:

1. Press “Menu” to enter the setting state, setting value would flash.
2. Press “◀ ” to decrease the setting value. Press “▶ ” to increase the setting value.
3. After step 2, press “Menu” to save the setting, press “Esc” to back out.

3.3 Parameters Browsing

3.3.1 Battery

1. : **% Low V: **V I: **A



**%— Percentage of battery power



Right corner have below displays:

Low—Battery over-discharge protecting

Normal—Battery is normal

Full—Battery over-charge protecting;

Float—Floating

Ft: **s —Countdown of exiting float (countdown start from 30s)



V—Battery voltage



I—Battery charging voltage

3.3.2 Solar

2. Solar : V: **V I: **A



V—Solar voltage



I—Solar charging current

3.3.3 Wind

3. Wind: **R/min V: **V I: **A



****R/min**— rotating speed of wind generator. (Normal working state is this display)

Other displays:

W1: Brake—wind generator is manually braked

W2: **S—when battery voltage is greater than “Full”, generator is braking. Exit braking “Time” countdown.

W3: **S—when rotate speed of wind generator is greater than “Rota”, generator is braking. Exit braking “Time” countdown.

W4: **S—when wind generator voltage is greater than “Vmax”, generator is braking. Exit braking “Time” countdown.

W5: **S—when wind generator current is greater than “Amax”, generator is braking. Exit braking “Time” countdown.

W*: Stay—Exit braking “Time” countdown finish, wind generator still stay brake.



“Full” could be set in 5/9 of 3.4.

“Rota” could be set in 2/9 of 3.5.

“Vmax” could be set in 6/9 of 3.5.

“Amax” could be set in 7/9 of 3.5.

“Time” could be set in 8/9 of 3.5.



V—wind output voltage



I—wind charging current

4. Wind-Power P: **W I: **A



V—wind output power



I—wind output current

3.3.4 Input

5. In-Power: **W S: **W W: **W



In-Power—total input power



S—solar input power



W—wind input power



3.3.5 Total Generated Energy

```
6.Total-Energy:
    **W • h
```

 **Total-Energy**—total generated energy
This value is cumulative. If want to start from 0, set in 2/9 of 3.4.





3.3.6 Temperature Protection

```
7. TP: Normal    **C
   TM:Normal    **C
```

 **TP**—controller device working temperature
 **TL**—MOS fet temperature
Normal: temperature is normal. Error: temperature detection module is error.
OTP: over-temperature protection **C: **Celsius degree



3.3.7 Error Code

```
8.ErrCode:
  B*  S*  W*  T*
```

 **B1**—battery over-discharge
B2—battery over-charge
 **S1**—solar input voltage is high
S2—solar charging module short-circuit fault
S3—solar charging module open-circuit fault
 **W1**—wind generator is manually braked
W2—battery voltage is greater than “Full”, wind generator brakes
W3—wind generator rotate speed is greater than “Rota”, generator brakes
W4—wind generator voltage is higher than “Vmax”, generator brakes
W5—wind generator current is greater than “Amax”, generator brakes
W6—brake module short-circuit fault
W7—wind charging module short-circuit fault
W8—wind charging module open-circuit fault
W9—wind input voltage is high
 **T1**—MOS fet detection module fault
T2—MOS fet over-temperature protection
T5—controller device detection module fault
T6—controller device over-temperature protection
 * **0**—normal state

3.3.8 USB (This is optional function, if not purchase, there is no the following display)

```
A1.      ****_**_**
USB**    **:**.**:**
```

 ****_**_**—Year-Month-Day。 Values could be set in 3.7
 **USB****—USB state
USB interface has the following states:
USBOK—USB well connected
USBNC—USB not connected
USBdErr—USB conversion module damaged or not connected
USBFULL—USB stick is full
 **:**.**:**—Hour: Minute: Second. Values could be set in 3.7

3.3.9 RS485 (This is optional function, if not purchase, there is no the following display)

A2. Device-Addr:
1

Device-Addr— Device address, for Modbus communication

3.3.10 Anemometer (This is optional function, if not purchase, there is no the following display)

A3. Wind-Speed:
***m/s

Wind-Speed—Wind speed

3.4 System Information

Main Menu
◀ 1. System Info ▶

System Info—system information

1. System Info
◀ Energy: ADD 2/9 ▶

Energy—ADD: Energy cumulates
CLEAR: Energy clears to 0

1. System Info
◀ RLow: **V 4/9 ▶

RLow—battery over-discharge limit
recovery voltage

1. System Info
◀ RFull: **V 6/9 ▶

RFull—battery over-charge limit
recovery voltage

1. System Info
◀ Out: **V 8/9 ▶

Out—over load limit voltage
This controller has no output.

1. System Info
◀ Batt: **Ah 1/9 ▶

Batt—battery capacity

1. System Info
◀ Low: **V 3/9 ▶

Low—battery over-discharge limit voltage

1. System Info
◀ Full: **V 5/9 ▶

Full—battery over-charge limit voltage

1. System Info
◀ Flot: **V 7/9 ▶

Flot—floating voltage

1. System Info
◀ ROut: **V 9/9 ▶

ROut—over-load limit recovery voltage
This controller has no output.

3.5 Wind Information

Main Menu
◀ 2. Wind Info ▶

Wind Info—wind information

2. Wind Info
◀ MPPT: ON 1/9 ▶

MPPT—wind MPPT function switch.
ON: turn on OFF: turn off
If do not purchase the function of Boost/Buck/Boost
& Buck, it would display “NONE”.

2. Wind Info
◀ Rota: **R 2/9 ▶

Rota—maximum rotate speed of
wind generator.

2. Wind Info
◀ Pole: **D 3/9 ▶

Pole—wind generator pole logarithm



Brake—manual braking switch
ON: turn on OFF: turn off

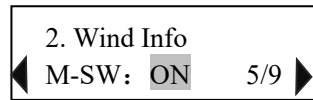

M-SW—wind charging manual switch
ON: turn on OFF: turn off

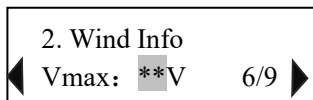

Vmax—Maximum voltage of wind generator

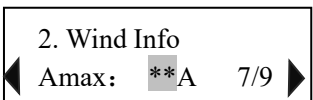

Amax—Maximum current of wind generator

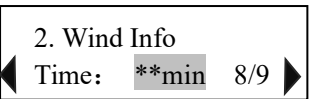

Time—braking time

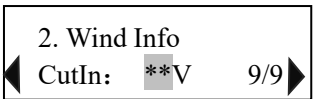

CutIn—wind start charging voltage
If do not purchase the function of Boost or Boost & Buck, it would display “NONE”

3.6 Solar Information

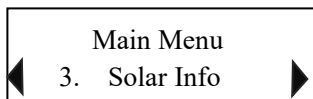

Solar Info—solar information

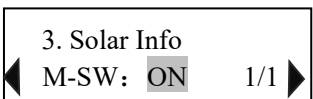

M-SW—wind charging manual switch
ON: turn on OFF: turn off

3.7 Date and Time Setting (If don't purchase the USB function, there is no the following display)

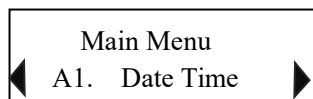

Date Time—date and time

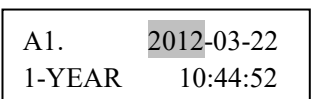

1-YEAR—“year” setting

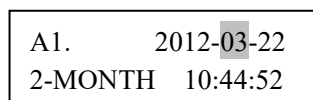

2-MONTH—“month” setting

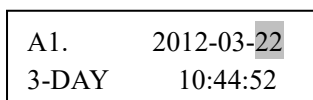

3-DAY—“day” setting

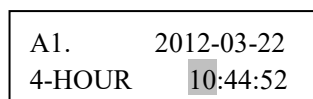

4-HOUR—“hour” setting

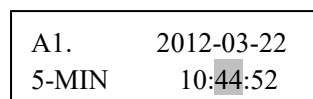

5-MIN—“minute” setting

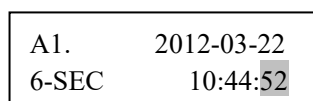

6-SEC—“second” setting

4 Software

The software is easy to operate need not to be installed. You can browse and set parameters on PC through the software. Users could ask the software from sellers.

- Browsing interface on PC:

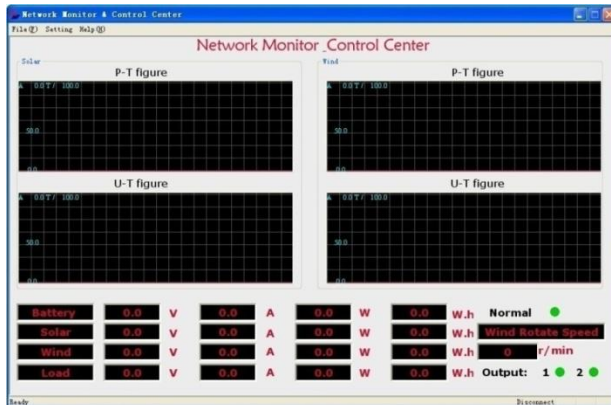

- Contents displayed on browsing interface:
Battery: voltage; charging current; power; power obtained; generated energy obtained.
Solar: voltage; charging current; charging power; generated energy.
Wind turbine: voltage; charging current; charging power; generated energy.
Output load: voltage; current; power; output energy.
- Software using method could reference to the instruction of software compressed file.

5 Warranty

The product is warranted for one year from the date of shipment to the original end user. During warranty period, if failure occurs when the product normal using, our company will repair or replace the failure product.

Out of warranty period, we supply repair service, but for charges.

This warranty is only provided to buyers who have bought the product and signed the CI with us, and the warranty is nontransferable.

Our company reserves the right to change products and without notice when products update.

This warranty does not apply under the following conditions:

- Damage by not operating in accordance with user manual.
- Damage by accident, negligence, abuse or improper use.
- Unauthorized product modification or attempted repair.
- Damage occurring during shipment

Parameters

Wind Solar Hybrid Controller (Boost & Buck)

Model	HY-C10-24BSLS	HY-C10-48BSLS
Rated wind power	1KW	1KW
Rated solar power	300W	500W
External dump load device	NO	NO
Nominal system voltage	24.0 V(adjustable)	48V
Battery over-discharge limit voltage(Low)	20.4 V(adjustable)	40.8V(adjustable)
Battery over-discharge limit recovery voltage(Rlow)	23.0 V(adjustable)	46.5V(adjustable)
Battery over-charge limit voltage(Full)	29.4 V(adjustable)	58.8V(adjustable)
Battery over-charge limit recovery voltage(RFull)	26.4 V(adjustable)	52.8V(adjustable)
Float voltage(Flot)	27.0 V(adjustable)	54.0V(adjustable)
Wind dumpload rotate speed(Rota)	800R(adjustable)	800R(adjustable)
Wind pole logarithm(Pole)	4D(adjustable)	4D(adjustable)
Wind charging range	DC (10-80)V	DC (20-100)V
Wind start charging Rota(CutIn)	300R(adjustable)	300R(adjustable)
Wind dumpload voltage(Vmax)	80V(adjustable)	100V(adjustable)
Dump load control mode	Over rotate speed limiting, Over voltage limiting, Over Current limiting, PWM	
Wind charging mode	MPPT(Boost & Buck) & PWM	
Solar charging mode	PWM	
Display mode	LCD	
Display content	Battery: voltage;charging current; Percentage of battery power. Solar: voltage; charging current.	
	Wind: voltage; charging current; rotate speed; output current; output power System: state; generated energy; error code	
Operating temperature & Relative humidity	- 20~ + 55 °C/35~85%RH(Non-condensing)	
Quiescent power drain	≤3W	
Protection type	Battery: over-discharge protection; over-charge protection; anti-reverse connection. Wind: Over rotate speed protection, over voltage protection, over current protection.	
Controller size	450mm*423mm*174.43mm	
Package size	510mm*250mm*545mm	
Net weight	15.5Kg	
Gross weight	17.0Kg	
Optional function	<input type="checkbox"/> RS232	
	<input type="checkbox"/> RS485	
	<input type="checkbox"/> USB	
	<input type="checkbox"/> Anemometer function	

FUORI RETE

SNA 3-6K (Monofase)

- Commutazione senza interruzioni off-grid
- 2 MPPT, Max. potenza di ingresso PV: 9,6 kW
- Ampio intervallo di tensione in ingresso PV: 100~500V
- Supporta fino a 18 unità in parallelo
- Corrente massima di carica e scarica: 140A
- Porta dedicata: Supporta generatore, accoppiamento AC o gestione intelligente del carico per una maggiore stabilità
- Monitoraggio in tempo reale 24/7 tramite l'app LUX con aggiornamenti senza preoccupazioni

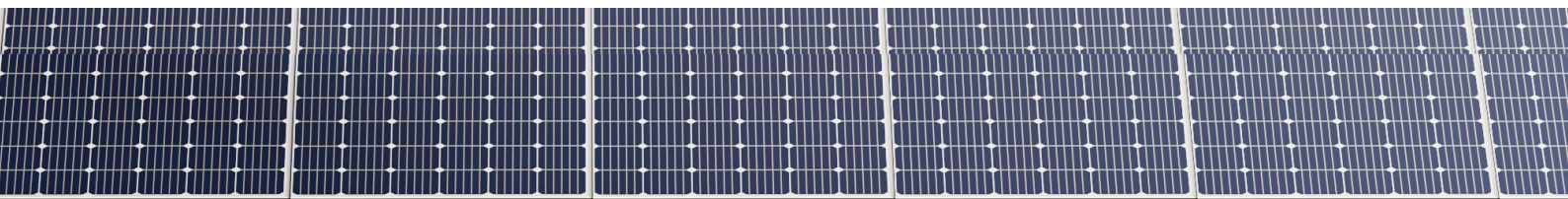
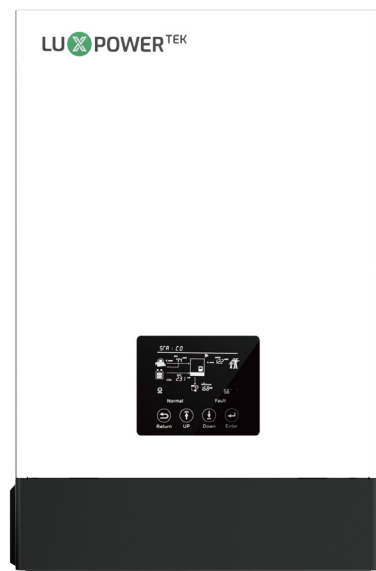

Modello	SNA 3K	SNA 4K	SNA 5K	SNA 6K
Ingresso (PV DC)				
Potenza massima di ingresso PV (W)	6000 (3000/3000)	8000 (4000/4000)	8000 (4000/4000)	9600 (4800/4800)
Tensione nominale di ingresso PV (V)	320			
Numero di ingressi MPPT indipendenti	2 / (1:1)			
Tensione massima di ingresso PV (V)	500			
Intervallo di tensione MPPT (V)	120 ~ 385			
Tensione di avvio (V)	100			
Corrente massima di ingresso PV per MPPT (A)	17 / 17			
Corrente massima di cortocircuito di ingresso PV per MPPT (A)	25 / 25			
Batteria				
Tipo di batteria compatibile	Litio-Ione / PbAcido			
Tensione nominale della batteria (V)	48			
Intervallo di tensione della batteria (V)	38.4 ~ 60			
Corrente massima di carica / scarica (A)	70/70	90/90	110/110	140/140
Potenza massima di carica / scarica (W)	3000	4000	5000	6000
Funzione di risveglio forzato della batteria da PV	Sì			
Funzione di risveglio forzato della batteria da rete	Sì			
Rete				
Tensione nominale AC (V)	230			
Frequenza nominale AC (Hz)	50 / 60			
Corrente nominale di uscita AC (A)	13.5	17.5	22	26.5
Potenza nominale di uscita AC (W)	3000	4000	5000	6000
Potenza massima di ingresso AC (W)	8000			9000
Fattore di potenza (FP)	0.99			
Distorsione armonica totale (THDI)	< 5%			
Corrente continua massima di passaggio AC (A)	35			40
Generatore (GEN)				
Tensione nominale generatore (V)	220 / 230 / 240			
Frequenza nominale generatore (Hz)	50 / 60			
Corrente nominale di ingresso generatore (A)	32			
Potenza nominale di ingresso generatore (W)	7370			
UPS				
Potenza di uscita nominale (W)	3000	4000	5000	6000
Tensione di uscita nominale (V)	230			
Corrente di uscita nominale (A)	13.5	17.5	22	26.5
Frequenza di uscita nominale (Hz)	50 / 60			
Potenza di sovratensione, durata	2 × potenza nominale per 5s			
Tempo di commutazione	<10ms in modalità singola / <20ms in modalità parallela			
Forma d'onda	Onda sinusoidale			
THDV	3%			
Efficienza				
Massima efficienza MPPT	99.9%			
Efficienza UE	94.7%			
Massima efficienza	93.0%			
Efficienza massima di carica / scarica	93.0%			
Protezione				
Protezione contro sovracorrente / sovratensione	Sì			
Protezione contro cortocircuito AC	Sì			
Monitoraggio della rete	Sì			
Protezione contro sovratensione AC	Tipo III			
Protezione contro inversione di polarità della batteria	Sì			
Generale				
Dimensioni (L × A × P)	330 × 505 × 135 mm / 13 × 19.9 × 5.3 in			
Peso	14.5 kg / 32 lbs			
Classe di protezione	IP20			
Intervallo di temperatura ambiente di funzionamento (°C)	0 ~ 50			
Intervallo di temperatura di stoccaggio (°C)	-15 ~ 60			
Umidità relativa	5 ~ 95%			
Display & Interfaccia di comunicazione	LCD + LED, RS485 / Wi-Fi / CAN			
Garanzia	2 anni			
Metodo di raffreddamento	Raffreddamento intelligente			
Topologia	Senza trasformatore			
Altitudine massima di funzionamento (m)	2000			
Emissione acustica (dB)	50			
Norme e certificazioni				
IEC 62109-1/2, IEC 61683, EN 61000, MEA, PEA				